



## Performance Under Pressure: Cast-in-Place (CIP) Concrete Walls

IFAS Extension | School of Natural Resources and Environment | Program for Resource Efficient Communities | [www.energy.ufl.edu](http://www.energy.ufl.edu)



Hurricane Frances barrels down on Southeast Florida, September 3, 2004.  
(Source: NOAA)

### *2004: A Year to Remember...*

Over an unprecedented six week period from mid-August through the end of September 2004, Florida suffered through four hurricanes, including three major storms, category 3 or higher, when they made landfall. Tropical storm activity in Florida during this period was the highest for any single state in the last 130 years. Damages have been estimated at nearly \$60 billion and 117 Florida residents lost their lives during the 2004 hurricane season.

The unfortunate residents of Southeast Florida were especially busy as Hurricane Frances came onshore at Sewell's Point on September 5, 2004 while Hurricane Jeanne's eye passed over the southern end of Hutchinson Island only five miles away and less than three weeks later. Floridians won't soon forget the 2004 hurricane season and many residents are now searching for ways to secure their property and ensure their safety for the future storms that will inevitably arrive.

### *Building a More Durable Home*

One way of ensuring a new home's safety is to build it using durable, hurricane-resistant construction systems. A great example is the cast-in-place (CIP) concrete wall system. These walls can be created with either removable forms or those that are left in place after the wall has been poured, such as insulated concrete forms (see our ICF fact sheet). For both builders and homeowners, many benefits can come from removable and reusable forms. This fact sheet reviews the benefits of this strengthened wall system.

Our case study home, built by Mercedes Homes in Melbourne, Florida, is a prime example of this system in action. Mercedes Homes reuses modular aluminum forms to pour 6" thick CIP concrete walls. The concrete walls' R-value and radiation resistance is increased by placing a ¾" foil-faced rigid foam sheathing on the interior side of the wall. Mercedes Homes is the fifth largest homebuilder in Florida and has built over 1,000 CIP concrete homes.



Mercedes Homes raises the reinforcing steel for their next cast-in-place concrete wall home.  
(Source: Mercedes Homes)

**Seville Model (1-Story)**

**Location** | Melbourne, FL

**Builder** | Mercedes Homes

**Living Space** | 3/2 @ 1,978 ft<sup>2</sup>

**Total Under Roof** | 2,700 ft<sup>2</sup>

**Price** | \$247,908

**HERS Rating** | 88

**Wall** | Cast-in-Place Concrete

**Concrete** | 3,000 psi (6" slump)

**Vertical Rebar** | #5 @ 24" O.C.

**Wire Mesh** | 6" x 6"

**Tie-Down** | USP Structural Connectors (HTA16)

**Performance Under Pressure**

Sure, cast-in-place (CIP) concrete walls sound like a durable building system, but how do they perform in the high wind load conditions of hurricanes and tornados?

In laboratory testing conducted by the Wind Science and Engineering Research Center at Texas Tech University concrete walls were far superior to both conventional wood and steel framed walls when wood stud debris "missiles" were fired at the walls in conditions simulating a tornado with 250 miles per hour winds (a speed greater than 99% of all the tornados spawned in the United States and considerably higher than the 155 mph and higher wind speeds of Category 5 hurricanes). In these conditions a piece of wind-borne debris would travel up to 100 miles per hour. An excerpt from this study is shown below.

Wall Type	Test Wall Description	Speed of Debris	Results
Wood Frame	5/8" gypsum board interior finish, 2 x 4 wood studs at 16" o.c., 3-1/2" batt insulation, 3/4" plywood sheathing, vinyl siding exterior finish	109.0 mph	The debris "missile perforated completely through the wall assembly. Little damage to missile.
Steel Frame	5/8" gypsum board interior finish, steel studs at 16" o.c., 3-1/2" batt insulation, 3/4" plywood sheathing, vinyl siding exterior finish	103.5 mph	The debris "missile perforated completely through the wall assembly. Little damage to missile.
Concrete	6" thick reinforced concrete wall, #4 vert. reinforcing bars, 24" o.c. No finishes	102.4 mph	No cracking, front face scabbing or back face spalling of concrete observed.

(Source: <http://www.cement.org/homes/brief07.asp>)



A mock-up of the Mercedes Homes cast-in-place concrete wall next to a standard CMU wall.

(Source: Mercedes Homes)

Beyond the missile test, CIP concrete walls have proven to provide safe haven from other damaging forces resulting from high wind conditions. **NOTE, this data is for demonstration only and not to be used for design purposes.**

6" CIP Concrete Wall vs. 2" x 4" Wood Stud Wall with 1/2" Sheathing Test Conditions: 28.9 psf wind load (~125 mph storm)		
	Concrete Wall	Wood Stud Wall
<i>Axial Compression</i>	7,680 lbs/ft	400 lbs/ft
<i>Bending Moment</i>	2,158 ft-lbs/ft	350 ft-lbs/ft
<i>Shear</i>	3,960 lbs/ft	< 400 lbs/ft

(Source: Mercedes Homes and Will Swanson. Concrete wall features used to obtain these capabilities = 3,000 psi concrete, #5 @24" O.C. (vert. rebar in middle of wall with 60 ksi steel grade), 6"x6" wire mesh (60 ksi steel grade), 8' high by 16' long wall.)



A cast-in-place concrete wall shortly after pouring and placement of truss tie-down embeds.

(Source: Mercedes Homes)

### Variables Affecting Performance

The strength of any cast-in-place (CIP) concrete wall system comes from the combination of the concrete itself and the reinforcing steel utilized. It is important to remember that an engineer must be used to design any CIP concrete wall system. There are a few important variables to take into consideration when designing your CIP concrete wall systems.

1. Height and length of wall
2. Thickness of concrete
3. Size and placement of steel reinforcing and tie-downs
4. Size, placement, and quality of windows and doors
5. Slender wall buckling
6. Shear transfer to perpendicular walls (floor and roof diaphragms, X bracing, etc.)

To discover more about CIP concrete walls and view a sampling of producers/suppliers of removable form systems, visit the following websites:

- Concrete Homes Council: An Alliance of the Concrete Foundations Association (CFA)
  - <http://www.concretehomescouncil.org/>
- Portland Cement Association - Removable Forms (Cast-in-Place)
  - [http://www.cement.org/homes/ch\\_bs\\_removable.asp](http://www.cement.org/homes/ch_bs_removable.asp)



A Mercedes Homes metal-form panel awaits placement on a new home.

Source: Mercedes Homes

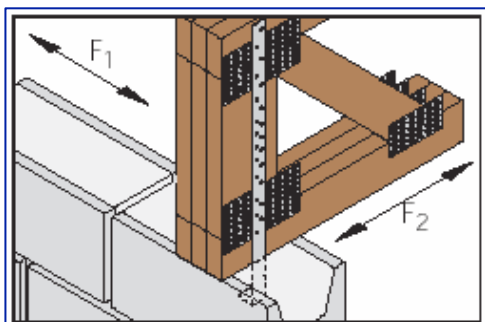

USP Structural Connectors embedded truss anchor HTA24-18.

Source: [www.uspconnectors.com](http://www.uspconnectors.com)

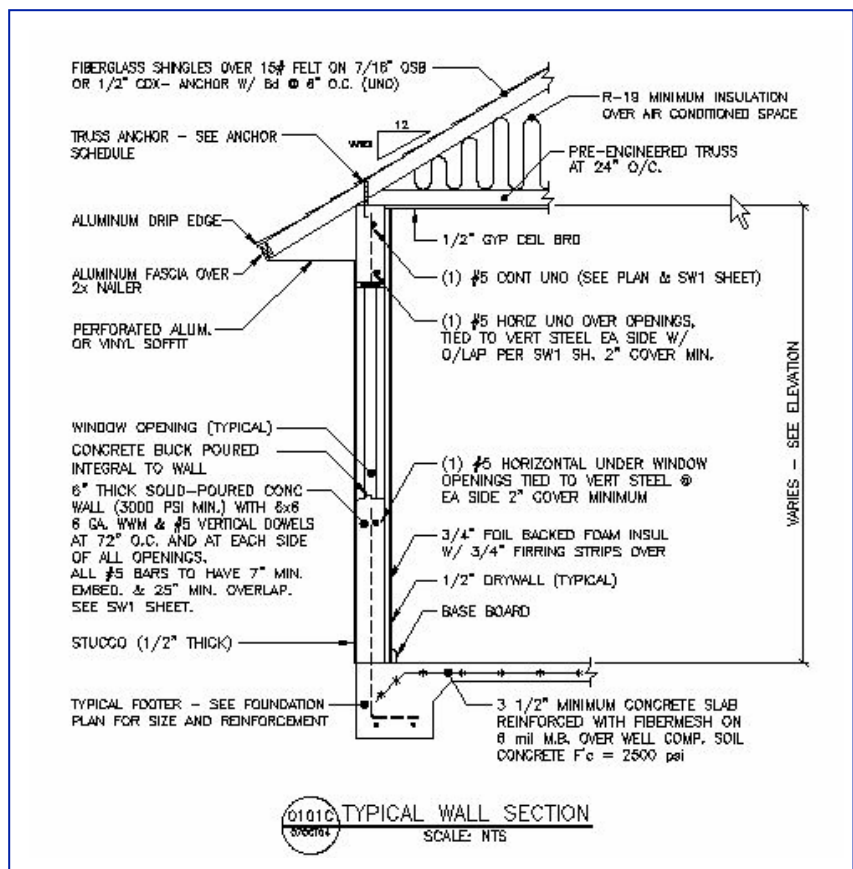

Typical wall section for the Mercedes Homes 1-story CIP concrete wall.

Source: Mercedes Homes

## *Other Benefits of CIP Concrete Walls & the Mercedes Homes System*

### Energy Efficiency and Comfort

- Concrete walls have a high thermal mass, which reduces home energy costs by decreasing the energy transfer between the outside and inside of the walls. These walls create more comfortable homes by minimizing interior temperature fluctuations and drafts.
- Concrete walls can help homeowners pursue energy-efficient mortgages.
- As a partner in the U.S. DOE Building America Consortium for Advanced Residential Buildings (CARB), Mercedes Homes further improves the energy efficiency of its homes, such as the Seville Model, by placing the air handling unit in conditioned space, mastic sealing the ducts, and installing low-E insulated windows.

### Noise Suppression

- According to the Portland Cement Association, concrete walls reduce noise transmission over 80 percent compared to wood-framed walls.

### Class A Fire Rating

- A 6" solid monolithic concrete wall offers 3-hour fire protection.

### Improved Indoor Air Quality

- Concrete walls resist moisture, mold, and mildew.

### Durability

- Concrete walls are termite and rot proof.
- Mercedes Homes is now working with the FEMA, the University of Florida Program for Resource Efficient Communities, and insurance underwriters to develop windstorm-resistance specifications for CIP concrete homes that will qualify homeowners for discounts on their homeowner insurance premiums.

## *Sources*

Partnership for Advancing Technology in Housing (PATH) - Concrete Formed Homes

- <http://www.toolbase.org/tertiaryT.asp?DocumentID=2008&CategoryID=1080>

Partnership for Advancing Technology in Housing (PATH) - Demonstration Site: Mercedes Homes/FEMA (Melbourne, Florida)

- <http://www.pathnet.org/sp.asp?id=1340>

Portland Cement Association (PCA) - Removable Forms (Cast-in-Place) Concrete Building Systems

- [http://www.cement.org/homes/ch\\_bs\\_removable.asp](http://www.cement.org/homes/ch_bs_removable.asp)

South Florida Sun-Sentinel - Hurricane Headquarters

- <http://www.sun-sentinel.com/news/weather/hurricane/>

U.S. DOE Building America: Consortium for Advanced Residential Buildings (CARB) - Mercedes Homes

- <http://www.carb-swa.com/projects.html#Mercedes>

U.S. DOE Building America: Consortium for Advanced Residential Buildings (CARB) - CARB News (Vol. 4, No. 12 - June 2001)

- <http://www.carb-swa.com/PDF%20files/June2001pdf.pdf>

USP Connectors - HTA16 Embedded Truss Anchor

- [http://www.uspconnectors.com/pdf-full-line-2005/Searchable\\_Menu\\_PDF/162-163and218.pdf](http://www.uspconnectors.com/pdf-full-line-2005/Searchable_Menu_PDF/162-163and218.pdf)